

WEST BENGAL ZOO AUTHORITY

Aranya Bhawan, 7th Floor, Block - LA-10A, Sector – III, Salt Lake City,
Kolkata – 700 106, West Bengal

Phone : + 91 33 2335 5011 (EPABX), FAX : + 91 33 2335 0012

E-mail: mswbza@gmail.com, wbzooauthority@yahoo.in

No: 22/6/WBZA/18-19

Dated:14/01/19

e-TENDER NOTICE

NIT No. 22/6/WBZA/18-19

(Construction of STORE CUM KITCHEN AT SUNDARBAN WILD ANIMAL PARK, JHARKHALI)

Member Secretary, West Bengal Zoo Authority invites e- tender for the following work(s) from the Eligible Contractors as detailed in the table below.

Sl. No.	Project No.	Name of the Work	Estimated Amount (without contingency) (Rs)	Earnest Money @2% of estimated value (Rs)	Price of Technical & Financial Bid documents & other annex only for L1 at the time of Award of Contract (AOC)	Period of Completion (Months)
1		Construction of STORE CUM KITCHEN AT SUNDARBAN WILD ANIMAL PARK, JHARKHALI	26,64,601/-	53,292/-	2000	6

Sl. No.	Particulars	Date & time
1	Date of uploading of N.I.T. Documents (online) (Publishing Date)	15 / 01 /2019
2	Documents download/sell start date & time (Online)	15 / 01 /2019
3	Bid submission and download start date (On line)	15 / 01 /2019
4	Bid Submission closing (On line)	30 / 01 / 2019 (3.00 pm)
5	Last date of submission of original copies of demand draft for Earnest Money Deposit offline in the office of the Member Secretary, West Bengal Zoo Authority at the above address	Upto Closing date of submission of Bid
6	Date of opening of Technical Bid (Online)	01 / 02 / 2019 (3.00 pm)
7	Date for opening of Financial Bid (Online)	06 / 02 / 2019 (3.00 pm)

Detail of e-TENDER Notice, Terms and Conditions, BOQ, etc will be available from website

<http://wbtenders.gov.in>

1. In the event of e-filling, intending bidder may download the tender documents from the website <https://wbtenders.gov.in> directly with the help of Digital signature Certificate. Necessary Earnest Money may be remitted through Demand Draft issued from any Authorized Banks & Banks included in Finance Dept Memo no 6426-F(Y) Kolkata 25/7/12 in favour of **West Bengal Zoo Authority** , payable at Kolkata and scanned copy to be uploaded during online submission of tenders.
2. Both **Technical Bid** and **Financial Bid** are to be submitted concurrently duly digitally signed in the website <https://wbtenders.gov.in>
3. Tender documents may be downloaded from website and submission of Technical Bid and Financial Bid will be done as per prescribed Time Schedule.
4. The **FINANCIAL OFFER** of the prospective tenderer will be considered only if the **TECHNICAL BID** of the tenderer is found qualified by the 'Tender Committee' formed by the "**Member Secretary, West Bengal Zoo Authority, Aranya Bhawan,7th Floor,Block-LA-10A, Sector –III, Salt Lake City, Kolkata - 700106.**
5. **Eligibility criteria for participation in the tender.**
 - 5.1 The prospective tenders as a primary agency should have satisfactorily completed at least 1 similar work within a period of 12 months for a magnitude of 50% of the amount put to the tender under the state Government or its undertaking or the Central Government or its undertaking or any Statutory Body during the last 3 (Three) years from the date of issue of the Notice And verifiable letters/ documents supporting it should be submitted along with Technical Bid.
 - 5.2 The Tenderer should have annual turnover more than 20% of the Estimated amount in each year during last 3 (Three) financial years or total more than 60% during last 3(three) financial years plus current financial year and supported with Audited Sheet /Audited Income tax documents/ return to be submitted along with Technical Bid.
 - 5.3 **Document:** Income Tax Acknowledgement Receipt for the latest Assessment year, P.T. Deposit Challan for the year 2016-17/2017-18 , PAN Card, VAT Registration Certificate/Copy of Latest GST return, PF (Mandatory), ESI(Mandatory), Subject to approval of CZA, Service tax registration/return of ST-2/Copy of Latest ST-3 (if any), are to be accompanied with the Technical Bid Documents.

[Non-statutory documents]
 - 5.4 **Affidavit (Y):** The prospective bidders or any of their constituent partner shall neither have abandoned any work nor any of their contract have been rescinded, debarred or blacklisted during the last 3 (*three*) years by any Government or PSU. Such abandonment or rescission will be considered as disqualification towards eligibility. A declaration in this respect through affidavit has to be furnished by the prospective bidders without which the Technical Bid shall be treated as non-responsive and be submitted along with technical bid.
 - 5.5 Registered Labour Co-operative Societies are required to furnish valid Bye Law, Current Audit Report, Minutes of last A.G.M (preferably), valid certificate from A.R.C.S.

along with other relevant supporting papers and be submitted along with technical bid.

5.6 Earnest Money:

The amount of Earnest Money @ 2% (*two percent*) of the Estimated Amount put to tender in the shape of Bank Draft of any authorized banks & banks included in Finance Dept Memo no 6426-F(Y) Kolkata 25/7/12, Memo no. 7791 F(Y) dt 9/11/2015 & other orders thereof drawn in favour of the **West Bengal Zoo Authority , payable at Kolkata.** scanned copy be submitted along with **Technical Bid** and hard copy (original EMD) be submitted separately in the above office address within closing date.

6. Bid shall remain valid for a period of 90 days from the first date of closing. If the bidder withdraws the bid during the validity period of bid, the earnest money as deposited will be forfeited forthwith without assigning any reason thereof.

INSTRUCTION TO BIDDERS

General guidance for e-Tendering:

Instructions / Guidelines for electronic submission of the tenders have been annexed for assisting the contractors to participate in e-Tendering.

i) Registration of Contractor:

Any contractor willing to take part in the process of e-Tendering will have to be enrolled & registered with the Government e-Procurement System, through logging on to <https://wbtenders.gov.in> The contractor is to click on the link for e-Tendering site as given on the web portal.

ii) Digital Signature certificate (DSC):

Each contractor is required to obtain a Class-II or Class-III Digital Signature Certificate (DSC) for submission of tenders from the approved service provider of the National Informatics Centre (NIC) or other certified agencies of Government of India on payment of requisite amount. Details are available on the Web Site. DSC is given as a USB e-Token.

iii) The contractor can search & download N.I.T. & Tender Document(s) electronically from computer once he logs on to the website by using the Digital Signature Certificate (DSC). This is the only mode of collection of Tender Documents.

iv) Participation in more than one work:

A prospective bidder shall be allowed to participate in the job either in the capacity of individual or as a partner of a firm.

v) Submission of Tenders: Tenders are to be submitted through online to the website in two folders at a time for each work, one in Technical Proposal & the other is Financial Proposal before the prescribed date & time using the Digital Signature Certificate (DSC). The documents are to be uploaded virus scanned copy duly Digitally Signed. The documents will get encrypted (transformed into non readable formats).

Technical Proposal:

The Technical proposal should contain scanned copies of the following in two covers (folders)

(a) Statutory Cover Containing the following documents:

1. NIT
2. Scan copy of EMD
3. AFFIDAVIT – "Y"

(b). Non-statutory Cover Containing the following documents: As listed in eligibility criteria given in NIT Para 5.1 to 5.5.

N.B. : Failure of submission of any of the above mentioned documents as stated will render the tenderer liable to be rejected for both statutory & non statutory cover.

THE ABOVE STATED NON-STATUTORY/TECHNICAL DOCUMENTS SHOULD BE ARRANGED IN THE FOLLOWING MANNER

Click the check boxes beside the necessary documents in the My Document list and then click the tab " Submit Non Statutory Documents' to send the selected documents to Non-Statutory folder. Next Click the tab " Click to Encrypt and upload" and then click the "Technical" Folder to upload the Technical Documents.

1. Tender Evaluation Committee (TEC)1. Tender Committee constituted as per Order of the Director, WBZA, Department of Forests, Government of West Bengal will function as Chairman of Committee for selection of technically qualified contractors.
2. Opening of tender: Will be made as per sequence.
3. Opening of Technical Proposal: Technical proposals will be opened by the Director, West Bengal Zoo Authorities and his authorized Nodal officer electronically from the website using their Digital Signature Certificate (DSC).
4. Intending tenderers may remain present if they so desire.
5. Cover (folder) for Statutory Documents Will be opened first and if found in order, cover (folder) for Non-Statutory Documents will be opened. If there is any deficiency in the Statutory Documents the tender will summarily be rejected.
6. Decrypted (transformed into readable formats) documents of the non-statutory cover will be downloaded & handed over to the "Tender Committee".
7. Summary list of technically qualified tenderers will be uploaded online.
8. Pursuant to scrutiny & decision of the "Tender Committee" the summary list of eligible tenderers & the serial number of work for which their proposal considered will be uploaded in the web portals
9. During evaluation the committee may summon of the tenderers & seek clarification /information or additional documents or **Original hard copy** of any of the documents already submitted & if these are not produced within the stipulated time frame, their proposals will be liable for rejection.

AFFIDAVIT – "Y"

(To be furnished in Non Judicial Stamp paper of appropriate value duly notarized)

- 1) I, the under-signed do certify that all the statements made in the attached documents are true and correct. I have all machineries as per NIT & all will be at site during entire period of work. In case of any information submitted proved to be false or concealed, the application may be rejected and no objection/claim will be raised by the under-signed.
- 2) The under-signed also hereby certifies that neither our firm M/S..... nor any of constituent partner had been debarred to participate in tender by the any Government Department during the last 3 (three) years prior to the date of this N.I.T. I/We have presently..... nos. of works in my hand & I would finish the work in time.

- 3) The under-signed would authorize and request any Bank, person, Firm or Corporation to furnish pertinent information as deemed necessary and/or as requested by the Department to verify this statement.
- 4) The under-signed understands that further qualifying information may be requested and agrees to furnish any such information at the request of the Department.
- 5) Certified that I have applied in the tender in the capacity of individual/ as a partner of a firm/authorized representative of company or society and I will not handover the job to any other person except my employee to supervise.

Signed by an authorized officer of the firm.

Title of the officer

Name of the Firm with Seal

Date:

SPECIAL TERMS AND CONDITIONS

1. **Deployment of Qualified Engineer at Work Site**
 - a. The Contractor shall deploy Qualified Engineer having sufficient knowledge of structural civil engineering and electrical works to execute for Construction of Work costing Rs. 50 Lakh or above.
 - b. The work shall not be executed in absence of qualified Engineer.
2. No price escalation / price variation shall be allowed till completion of work including extended period of completion.
3. Refund of Security Deposit will only be made after successful maintaining of appropriate service level of the work for at least 12 (twelve) months from the date of completion of the work.
4. The prospective bidders or any of their constituent partner shall neither have abandoned any work nor any of their contract have been rescinded, debarred or blacklisted during the last 3 (*three*) years by any Government or PSU. Such abandonment or rescission will be considered as disqualification towards eligibility. (A declaration in this respect through affidavit has to be furnished by the prospective bidders without which the Technical Bid shall be treated as non-responsive.)
5. **Checking of Design and its Drawings**
 - 5.1 The contractor shall check all design and drawings developed by the Authorized firm of WBZA.
 - 5.2 The contractor shall discuss the deficiencies/discrepancies found in design and Drawings with the above authorized firm.
 - 5.3 The contractor shall ensure that designed parameters are within limits and specification of relevant IS codes and NBO whichever is applicable.
 - 5.4 In case of any differences of IS code or PWD/NBO provisions notice, the parameter of the provision providing higher safety and Durability of Structural Design shall be followed.
 - 5.5 in case of any difference of opinion found in developed design and checking design, it shall be discussed by both the parties to resolve it adherence of IS code with relevant Codal Provision and rectify accordingly with mutual agreements for correctness as per provision in respect of safety and durability of structure.

6. Variation in Quantities

- 6.1 The contractor shall execute the work upto enhancement of quantity of work of any of the item or nos. of items upto 25% more as included in the tender schedule on same accepted rates.
 - 6.2 The Contractor shall agree if any of the item or nos. of items quantities reduced by the Member Secretary, WBZA without any claim.
 - 6.3 In case of any new item or items not included in tender Schedule and is to be executed for construction upto the value of 25% more of tender estimated amount plus the value of items not operated which are included in tender schedule as decided by the Member Secretary, WBZA, the contractor shall submit his rates along with analysis for reasonability of rates so submitted. If tender committee finds the rates are on higher side, the contractor shall attend the negotiation with modified rates to finalize the item for execution and continuation of work without loss of time. The analysis submitted by the contractor shall be supported by the market rates if any of the item otherwise not appearing in PWD SOR/2015 and its components parts involved like Cement etc for which rates are already available in PWD SOR. The item which is available in PWD SOR but not in the tender Schedule, the analysis of rates shall be worked out as per Rates available in the PWD SOR against such items. In case the tender committee find it necessary to call for negotiation of accepted rate in contract for repercussion of deletion/variation of any major items, rate appearing on higher side, contractor should agree to negotiate freely with analysis of rates.
7. Assurance of Material's Quality- All materials test results should confirmed to IS code provisions. The test results not as per the provisions, the material lot and source shall be rejected for further procurement and the material so unloaded in store/site, shall be removed.
 - 7.1 **CEMENT-** the cement lot received in store/ at site for execution of work shall be procured from the approved manufactures (Ambuja, Birla, ACC etc) dealers/stock holders and the invoice/challan for dispatch and procurement payment bill etc shall be submitted with the authorized representative of the Director WBZA.
 - 7.1.1 The Cement Sample of the lot as decided by the authorized representative shall be collected and tested for its strength and setting times along with chemical tests in Govt. approved Labs. All arrangements shall be made by the contractor of its own cost.
 - 7.2 **Aggregates-**
 - 7.2.1 **Coarse aggregate** shall be procured from the approved dealer of Pakur Variety and invoice/challan for dispatch and procurement payment bill etc shall be submitted with the authorized representative of the Member Secretary, WBZA.
 - 7.2.2 The sample shall be collected from the lot unloaded at site for its testing in approved govt. lab for Crushing Strength, Water Absorptions, Flakiness and Elongation test, Abrasion and Impact/ California Tests. Or any other tests if necessary.
 - 7.2.3 The above sample may also be stored in transparent jar sealed for future quality comparison of the lot unloaded at site.
 - 7.2.4 **Fine aggregate** shall be procured from the approved mines/ river bed as specified in PWD SOR/West Bengal Mines Authority for use of construction work .

- 7.2.5 The lot sample shall be collected and tested in the approved govt. lab for Sieve Analysis, Fineness Modulus, Water Absorption, Chemical tests, Specific Gravity test etc.
- 7.2.6 The above sample may also be stored in transparent jar sealed for future quality comparison of the lot unloaded at site.
- 7.2.7 The moisture content as per varied climatic condition at site shall be tested for controlling the W/C ratio in Concrete mix.
- 7.2.8 The bulking of Fine Aggregate if so necessary shall be tested as per IS code.
- 7.3 **Reinforcement Steel-**
- 7.3.1 The reinforcement steel shall be procured from the approved dealer/stock Holder of the manufactures as listed in the schedule i.e. SAIL/TATA/RINL and the invoice/challan for dispatch and procurement payment bill etc shall be submitted with the authorized representative of the Member Secretary, WBZA.
- 7.3.2 The lot procured and unloaded at site/store shall ensure that each bar carry the manufacturer's trademarks.
- 7.4 **Water** used for Construction and Curing-
- 7.4.1 The source of water shall be decided before start of work.
- 7.4.2 The source so decided or developed Water sample shall be tested in Govt. approved lab.
- 7.5 **Admixture/Super-plasticizers**
- 7.5.1 ISO approved brand shall be procured from the authorized dealer of the manufacture.
- 7.5.2 The item collected in store/at site, shall be supported by invoice no, Technical Data Sheet for its genuine purchase.
- 7.6 **Concrete**
- 7.6.1 The casting of Concrete cubes shall be tested on prescribed frequency as per IS code or as directed by authorized representative of Member Secretary, WBZA.
- 7.6.2 The sample of concrete for casting the test cube shall be collected from that mixture as directed by authorized representative of Member Secretary, WBZA.
- 7.6.3 All the cube samples shall be carried out for the prescribed period with respect to date of casting as per IS code in the Govt. approved Lab.
- 7.6.4 The slump test shall be carried out at site of work as per IS code provision.
- 7.6.5 In case the test results not as per the provision, batch mix shall be cancelled and concrete shall be removed as directed by the representative by the Member Secretary, WBZA.
- 7.6.6 The mix design cubes shall be casted as per IS provision for specimen and shall be tested in approved Lab before start of concrete work.
- 7.7 **Brick**
- 7.7.1 First class brick procured source shall be decided before construction.
- 7.7.2 The material unloaded at site shall be supported by challan/invoice.
- 7.7.3 The required test shall be carried out as per IS code like Water Absorption, Crushing strength, ringing test as directed by the representative by the Member Secretary, WBZA.
- 8.0 **Pile Test-**
- 8.1.1 The periodic Pile Load test shall be arranged for selected site by the representative by the Member Secretary, WBZA.
- 8.1.2 If necessary the Ultrasonic test for pile shall be arranged by the contractor at his own cost.
- 9.0 Any other test so required shall be arranged and conducted by the contractor as per IS code provision for want of characteristics strength and any other reason.

10. **Refund of EMD:**
- 10.1 The Earnest Money of all the Technical unsuccessful tenderers deposited in favor of the concerned wbza will be refunded by the said WBZA, on receipt of application from tenderers.
- 10.2 The Earnest Money of all other tenderers shall be refunded after release of acceptance letter in favor of the qualified lowest bidder on receipt of application from tenderers, except the bidder who is awarded the contract work EMD shall be retained as Security Deposit.
11. The Agreement shall be drawn on non-judicial stamp paper valued Rs.100 and above between the Constructor/Company and Zoo Authority before start of work on issue of acceptance letter and release of work order. The Tender document/tender Booklet as Tender all terms and conditions, acceptance letter, work order with tender schedule including rates shall be a part of Agreement.
12. It shall be the responsibility of the Contractor/Company to get the approval of plan from the concerning Local Authority/Body.

PART - A GENERAL CONDITIONS

1.0 Registered Labour Co-operative Societies are required to furnish valid Bye Law, Current Audit Report, Minutes of last A.G.M (preferably), valid certificate from A.R.C.S. along with other relevant supporting papers.

2.0 The bidder participated in more than one tender, and appearing as the lowest (L1) bidder in all tenders or in some of the tenders, the technical committee shall decide the number of tenders to be accepted for award of tenders works based on the bidder financial status capacity as submitted in the technical bids arriving closer to the equivalent of the total requirements of eligibility against each tender. The bidder shall accept the decision taken by the tender committee. The bidder shall not have any right to choose the tenders to be awarded.

3.0 Design may change (even during execution) based upon decision of CZA/WBZA and Contractors will follow the revised drawings and construct work as per accepted rates.

4.0 **Running payment** for work may be made to the contractor as per availability of fund. The contractor may get a running payment if the gross amount of each running bill is **25%** & more of the agreement amount.

5.0 **Security Deposit:** Retention money towards performance Security amounting to 10% (*ten percent*) inclusive of EMD, of the value of the work shall be deducted from the running account bills. No interest will be paid on Security Deposit.

6.0 All materials required for the proposed work including **Cement of ISO / BIS APPROVED Manufacturers only, Steel, (TATA/SAIL/RINL only) , & all coarse**

aggregates of Pakur variety only sand and boulder, other materials shall be as specified and approved brand inconformity with relevant code of practice (latest revision) and PWD / SOR specifications, and shall be procured and supplied by the agency at their own cost only from "authorized dealers" as defined u/s 2(11) of the West Bengal Value Added Tax Act, 2003, including all taxes. Authenticated evidence for purchase of all materials are to be submitted along with receipted Challan and authenticated test certificate before start of work in stages. If required by the Engineer-in-Charge, further testing from any Government approved Testing Laboratory shall have to be conducted by the agency at their own cost. **Constructional Labour Welfare CESS @ 1% (one percent)** of cost of construction will be deducted from every Bill of the contractor.

7.0 There shall be no provision of Arbitration. Hence Clause 25 of 2911(ii) stands omitted vide notification no 558/SPW dt. 13.12.2011 of Pr. Secretary, PW & PW (Roads) Deptt. In any dispute, which is even not solved after appealing to Member Secretary, WBZA dispute redressed committee vide GO no 8182-F(Y) Kolkata 26/9/2012 is to be followed.

8.0 No Mobilization /Secured advance will be allowed.

9.0 The contractor shall execute the work in such a manner so that steady proportionate progress of the work is maintained during execution of work.

10.0 **Refund of Security Deposit** will only be released after successful maintaining of appropriate service level of the work at least for 12 (twelve) months from the date of completion of the work to the entire satisfaction of the Engineer-in-Charge is mandatory.

10.1 If any defect / damage are found during the period as mentioned above, the contractor shall make the same good at his own cost true to the specification at par with instant project work. On failure to do so, penal action against the contractor will be imposed by the Department as deemed fit.

11. Site of work and necessary drawings shall be provided to the contractor in phase wise. No claim in this regard will be entertained.

12. The Bidder, at his own responsibility and risk is advised to visit and examine the site of works and its surroundings and obtain all information that may be necessary for preparing the Financial Bid and entering into a contract for the work as mentioned in the Notice Inviting Tender, before submitting offer with full satisfaction, the cost of visiting the site & expenditure, if any, shall be at his own expense. This office is not liable for any local problems/hindrance and bidders are requested to follow necessary steps as per Laws & procedure thereof.

13. The intending Bidders shall clearly understand that whatever may be the outcome of the present invitation of Bids, no cost of Bidding shall be reimbursable by the Department.

14 The intending tenderer are required to quote the rate *online*.

15 Contractor shall have to comply with the provisions of **(a)** the contract labour (Regulation Abolition) Act. 1970 **(b)** Apprentice Act. 1961 and **(c)** minimum wages Act. 1948 **(d)** Indian Forest Act, 1927 & amendments **(e)** Wildlife (Protection) Act 1972 & amendments of the notification thereof or any other laws relating thereto and the rules made and order issued there under from time to time.

16 During scrutiny, if it comes to the notice of the tender inviting authority that the credential or any other paper found incorrect / manufactured / fabricated / fake, such Tenderer bids shall be rejected without any prejudice bids, bidder would not be allowed to participate in the tender.

17 The Member Secretary, West Bengal Zoo Authority, Government of West Bengal reserves the right to cancel the N.I.T. due to unavoidable circumstances and no claim in this respect will be entertained.

18 The contractor's any of the document on verification if found incorrect / manufactured / fabricated / fake or false in that case awarded contract work liable to be terminated with imposition of penalties or penalized as deemed fit. The balance work shall be awarded on risk and cost basis tender.

19 Member Secretary/Director, WBZA decision shall be final and binding to follow in case of any discrepancy arises between two similar clauses contained in contract agreement.

20 The construction of the project work as mentioned in the schedule will have to be undertaken immediately on receipt of work order and the work must be completed as mentioned in the work order in conformity with "BAR CHART".

21 No extension of time will be allowed under any circumstances. (Except flood, earthquake, unforeseen reasons or any circumstances beyond control) Penalty of 1% for delay of 30 days, 2% for 45 days. Thereafter if work progress not improved, the work shall be terminated with forfeiture of EMD Security Deposit and Balance bill payments if so due and balance work shall be completed at risk and cost basis contract.

22 Materials will have to be procured by the contractors by themselves following the standard & specifications of PWD/PHE Schedules of the district, subject to the approval of the undersigned or his authorized Officers. Timber/logs must have valid receipt from registered dealer along with Transit Pass reference no. In case of supply of any material by the department, the cost of such material will be recovered from the bill of the Contractor.

23 The tenderers are required to inspect the sites, site plans and specifications of the works before submission of the tender and future ignorance of any such item will not be entertained. **The bidder should submit the list of EMP as earth movers, vibrator, concrete mixing machine, generator, welding equipments, etc.**

24 Royalty for any material, if obtained from Forest area, will have to be paid by the contractor. Even if the material is procured from other Govt. Deptt's resources, the receipt for payment of such material must be shown and photocopies to be

attached with the bill. Extra payment for such payment of Royalty etc. will not be entertained.

25 All tools & plants required for execution of the works should be owned / hired in the name of Company or contractor at own cost.

26 Brick works, cement concrete works & plastering works and similar works which require curing should be done for the period as prescribed in the P.W.D. Schedule of Rates.

27 The Member Secretary, WBZA reserves the right to terminate the agreement at any point of time of execution of the work within the schedule of time of completion of the tendered work, If performance quality and / or progress of various items of work are not satisfactory, or delayed or violate any term & condition of agreement.

28 The contractor is liable to pay the skilled, unskilled and other labour wages as per existing rules. Local skilled Forest Protection committee members may be involved but is not mandatory.

29 Deduction of TDS & Labour wel-fare cess, if applicable shall be made as per rule in vogue. The total tender value will be exclusive of GST.

30 The successful tenderer will not assign the work or part of the work to any other contractor as sub contract work.

31 The contractor may, however authorize any person working under his firm on roll as employee to supervise the day to day work, submit the requisition of materials, attend the measurement when taken by the authorized officer and record his signature on the work measurement note books. The authority there to duly approved by the Director, WBZA or its authorized representative.

32 In case of any dispute the decision of the **"Member Secretary"**, WBZA will be final and binding for completion of work. However if contractor is not satisfied, he is liberty and free to represent to the higher Authority without suffering the progress.

33 The tender notice along-with all terms & conditions, tender Schedule as hausted on website for tender notice work will form the part of the agreement to be executed.

34 The Tender inviting authority reserves the right if practicable to split the work amongst the lowest bidders appearing with same rate or to award the work any one of two whose Credentials are superior over other. It is therefore requested to submit the list of works completed and list of works in progress along with work-wise details for last three years period including last three financial years turnover along with Audited sheets.

35 Location of the works will be finalized by the Member Secretary/Director, WBZA after joint inspection.

36 Any part while signing agreement realized as typographical mistake in case of Unit, Rate, Quantity, Amount, any type of nomenclature in items of works / item itself including description etc. shall not be altered and whatsoever as stated in documents shall be included in the agreement. The operation of such item is reasonable and practicable shall be decided by the Member Secretary/Director, WBZA whether to execute for construction or to drop and call for as additional new item rates as per contained in terms and conditions of tender.

37 **Work order will be issued subject to approval of fund from higher Authority.**

PART - B

GENERAL INSTRUCTIONS TO TENDERERS

1. INCOME TAX CERTIFICATES: A Certificate of Income tax clearance from the appropriate authority in the forms prescribed there for duly indicating annual turnover. These certificates shall be valid for one year from the date of issue or for the period prescribed therein for all tenders submitted during the period. Copy of last assessment order duly certified as true copy by the chartered accountant shall also be submitted.

2.0 Information on type of holding details of the Tenderers' organization shall be submitted as follows:

2.1 IN CASE OF FIRMS WITH SOLE OWNERSHIP: Full name, experience and address of the proprietor and nature of business.

2.2 IN CASE OF PARTNERSHIP FIRMS: The names of all the partners with addresses and their experience. A copy of the partnership deed/ instrument of Partnership duly certified by a Notary Public shall be enclosed.

2.2.1 The value of work shall be taken in the same proportion of share of partnership deed.

2.2.2 if the partnership deed do not speak of percentage share of each partner, it shall not be considered as Credential for qualifying Eligibility criteria.

2.3 IN CASE OF COMPANIES: Date and place of registration including date of commencement certificate in case of public companies and the nature of business carried out by the Company. Certified copies of memorandum and Articles of Association are also to be furnished. Also indicate names, addresses and experience of the Directors.

3. RETURN OF SECURITY DEPOSIT : If the contractor fully performs and completes the work in all respects to the entire satisfaction of WBZA and presents an absolute "**No Demand Certificate**" in the prescribed form and returns properties belonging to WBZA taken, borrowed or hired by him for carrying out the said works and shall be released only after the Guarantee Period of 12 months is completed satisfactorily.

4. No interest shall be payable by WBZA on Earnest Money Deposit, Security Deposit

or on any moneys due to the contractor.

5.0 COMMENCEMENT AND COMPLETION OF WORK

5.1 The contractor shall commence the work within the time indicated in the Letter of Intent / acceptance and shall proceed with the same with due expedition without delay. The responsibility of successful Tenderer under this Contract commences from the date of issue of the Letter of Intent.

5.2 If the successful tenderer fails to commence the work within the stipulated time, WBZA, at its sole discretion, will have the right to terminate the contract. The Earnest Money and/ or Security Deposit will stand forfeited without any further reference to him without prejudice to any and all of WBZA's other rights and remedies in this regard.

5.3 All the works shall be carried out under the direction and to the satisfaction of the Member Secretary/Director, WBZA.

6.0 MEASUREMENT OF WORK AND MODE OF PAYMENT

6.1 All payments shall be made in the name of contractor by Account's Payee Cheque.

6.2 For progress/running bill payments, the contractor shall present detailed measurement book and sheets in triplicate duly indicating all relevant details based on technical documents and connected drawings for the work done during the month. These measurement sheets shall be prepared jointly with Engineer and signed by both the parties.

6.3 These measurement sheets will be checked by the Engineer and quantities and percentages eligible for payment under different groups shall be decided by him. The abstract of quantities and percentages so arrived at based on the terms of payment shall be entered in the **Measurement Book** and signed by both the parties.

6.4 Based on the above quantities, contractor shall prepare the bills in the prescribed proforma and work out the financial value. These will be entered in the Measurement Book and signed by both the parties. Payment shall be made after affecting the necessary recoveries due from the contractor.

6.5 Measurement shall be taken jointly by persons duly so authorised by the Member Secretary/Director, WBZA and the Contractor and shall follow the relevant provisions of IS code and PWD / SOR 2017 for recording and taking measurements.

6.6 The Contractor shall bear the expenditure involved, if any, in making the measurements and testing of materials to be used/ used in the work. The Contractor shall, without extra cost to WBZA, provide all the assistance with appliances and other things necessary for measurement.

6.7 If, at any time due to any reason whatsoever, it becomes necessary to re-measure

the work done, in full or in part, the expenses towards such re-measurement shall be borne by the Contractor.

6.8 Final measurement bill shall be prepared in the proforma prescribed for the purpose, based on the certificate issued by the Engineer that the entire work as stipulated in the tender specifications has been completed in all respects to the entire satisfaction of WBZA. The Contractor shall give 'No Claim' and 'No Demand' certificates. All the tools and tackles loaned to him should be returned in condition satisfactory to WBZA. The abstract of final quantities and financial values shall also be entered in the Measurement Book and signed by both the parties.

7.0 RESPONSIBILITIES OF CONTRACTOR IN RESPECT OF LOCAL LAWS, EMPLOYMENT OF WORKERS, ETC.

The following are the responsibilities of the Contractor in respect of observance of local laws, employment of personnel, payment of taxes etc.:

7.1 As far as possible, unskilled workers shall be engaged from the local areas in which the work is being executed.

7.2 The contractor at all times during the continuance of this contract, shall in all his dealings with the local labour for the time being employed on or in connection with the work, has due regard to all local festivals, religious and other customs.

7.3 The Contractor shall comply with all State and Central Laws, Statutory Rules, Regulations, etc., such as The payment of wages Act, The Minimum Wages Act, The workmen's Compensation Act, The Employer's Liability Act, The industrial Disputes Act, The Employees' Provident Fund Act, Employees' State Insurance Scheme, the Contract Labour (Regulations and Abolition Act, 1970) and other Acts, Rules and Regulations for labour as may be enacted by the Government during the tenure of the Contract and having force or jurisdiction at site. The contractor shall give to the local Governing Body, Police and other concerned Authorities all such notice as may be required under law.

7.4 The Contractor, in the event of his engaging 20 or more workmen, will obtain independent license under the Contract Labour (Regulations and Abolition Act, 1970) from the concerned authorities based on the certificate (Form-V) issued by the principal employer.

7.5 The contractor shall pay all taxes, fees, license charges, deposits, duties, tolls, royalty, commissions or other charges which may be leviable on account of any of his operations connected with this contract. In case WBZA make any such payment, it shall be recovered from the contractor bill.

7.6 The contractor shall be responsible for the provision of health and sanitary arrangements more particularly described in the Contract Labour (Regulations and Abolition Act, 1970) and safety precautions as may be required for safe and satisfactory execution of the contract.

7.7 The contractor shall be responsible for proper accommodation including adequate medical facilities for the personnel employed by him.

7.8 The contractor shall be responsible for the proper behavior and observance of all regulations by the staff employed by him.

7.9 The contractor shall ensure that no damage is caused to any person / property of other parties working at site. If any such damage is caused, it shall be the responsibility of the contractor to make good the losses and compensate them.

7.10 Any delay in completion of works or non-achievement of periodical targets, due to reasons attributable to the contractor, will have to be compensated by the contractor either by increased manpower and resources at no extra cost to WBZA.

7.11 The contractor will be directly responsible for payment of wages to his workmen. A pay-roll sheet giving details of all payments made to the workmen duly signed by the contractor's representative should be furnished to the Director, WBZA, if called for.

7.12 In case of any class of work for which there is no specification laid down in the contract, such work shall be carried out in accordance with the instructions and requirements of the Engineer.

7.13 **No idle labour charges** will be admissible in the event of any stoppage of work resulting in the contractor's workmen being rendered idle due to any reason at any time.

7.14 The contractor shall keep the area of work clean and shall remove the debris etc while executing day-to-day work. Upon completion of work, the contractor shall remove from the vicinity of work, all scrap, packing materials, rubbish, unused and other materials and deposit them in places specified by the Engineer. The contractor will also demolish all the hutments, sheds, offices, etc. constructed and used by him and shall clean the debris. In the event of his failure to do so, the same will be arranged to be done by the Engineer and the expenses recovered from the contractor.

7.15 The contractor shall execute the work in the most substantial and workman like manner in the stipulated time. Accuracy of work and timely execution shall be the essence of this contract. The contractor shall be responsible to ensure that the quality, assembly and workmanship as per specifications and mode of operations conform to the required dimensions and clearance given in the drawings and/ or as per the instructions of the Engineer.

7.16 No land belonging to WBZA shall be occupied by the Contractor without written permission of the Member Secretary/Director, WBZA.

8.0 RESPONSIBILITIES OF CONTRACTOR IN RESPECT OF SAFETY OF MEN, EQUIPMENT, MATERIAL AND ENVIRONMENT.

8.1 one safety officer shall be deployed by the contractor to observe all safety rules and obeyed taken care of concerning working group of contractor. He will also council from time to time all fields staff. The contractor shall be responsible for the safety of the equipments /materials and work to be performed by him and shall maintain all

lights, fencing, guards, signs and other protection necessary for the purpose. The contractor shall arrange for such safety devices as necessary and shall carried out the requisite site test of handling equipments, lifting tools, tackles, etc as per usual standards and practices.

8.2 The contractor shall provide the listed items to it's work force and ensure the use of the following personal protective equipment as found necessary and as directed by the authorised WBZA officials.

- (a) Safety Helmets conforming to IS-2925
- (b) Safety Belts conforming to IS-3521
- (c) Safety shoes conforming to IS-1989
- (d) Eye, Ear & Face Protection devices conforming to IS-8520 and IS-8940, IS-5983
- (e) Hand & body protection devices conforming to IS-2573, IS-6994, IS-8807 & IS-8519.
- (f) Rubber gloves for electrical purposes confirming to IS-4770
- (g) Industrial safety gloves (leather & cotton gloves) confirming to IS-6994
- (h) Industrial and safety rubber knee boots confirming to IS- 5557

8.3 All tools, tackles, lifting appliances, material handling equipment, scaffolds, cradles, safety nets, ladders, equipment etc. used by the contractor shall be of approved brands.

8.4 All electrical equipment, connections and wiring for construction power, its distribution and use shall conform to the requirements of Indian Electricity Act and Rules. Only electricians licensed by the appropriate statutory authority shall be employed by the contractor to carry out all types of electrical works. All electrical appliances including portable electric tools used by contractor shall have safe plugging system to source of power and be appropriately earthed.

8.5 The contractor shall not use any hand lamp energised by electric power with supply voltage of more than 24 volts. For work in confined spaces, lighting shall be arranged with power source of not more than 24 volts.

8.6 Where it becomes necessary to provide and / or store petroleum products, explosives, chemicals and liquid or gaseous fuel or any other substance that may cause fire or explosion, the contractor shall be responsible for carrying out such provision and/or storage in accordance with the rules and regulations laid down in the relevant Government Acts, such as Petroleum Act, Explosives Act, petroleum and Carbides of Calcium Manual of the Chief Controller of Explosives, Government of India etc. Prior approval of the authorised WBZA official at the site shall also be taken by the contractor in all such matters.

8.7 No work at site shall be allowed to carry out after sunset unless it becomes necessary to complete the job and sufficient light arrangements and protection means adopted. Otherwise such situation to arise be avoided. The contractor shall have arrangement at his cost (wherever not specified) appropriate illumination at all work spots for safe working, when natural daylight may not be adequate for clear visibility.

8.8 In case of a fatal or disabling injury / accident to any person at construction sites due to lapses by the contractor, the victim and / or his / her dependents shall be

compensated by the contractor as per statutory requirements.

8.9 In case of any delay of progress due to lapse of the contractor or on Administrative ground, contractor shall apply the extension of period of contract for completion of work as per extended period.

8.10 Necessary precautions and arrangements including sprinkling of water during work as acceptable to WBZA for safety and reducing environmental pollution have to be made by the contractor. No claim on this account shall be entertained on this account and the contractor's rates shall be deemed to have taken this into account.

9.0 INSURANCE

9.1 WBZA shall not arrange for insuring the materials / property of WBZA covering the risks during transit, storage, erection and commissioning. The Contractor has to arrange on his own insurance pertaining to their scope of work for all workers and to arrange for accident risk policy/ workmen compensation policy, materials like Cement, Reinforcement steel and other bought out items and other valuable building materials during its transport, storage, till it goes to the permanent work, their all T & Ps and, IMTEs and fixed assets which they may acquire and deploy at site. Proper insurance cover against any eventuality such as earthquakes, floods and other calamities has to be taken by the contractor for constructed and completed structures at site till these are handed over to WBZA.

9.2 It shall be the sole responsibility of the contractor to insure his workmen against risks of accidents and injury while at work as required by the relevant Rules and to pay compensation, if any, to them as per Workmen's Compensation Act. The contractor shall also insure his staff against accidents. The work will be carried out in a protected area and all the Rules and Regulations of WBZA in the Project Area which are in force from time to time will be followed by the contractor.

9.3 If due to negligence and/or non-observance of safety and other precautions, any accident / injury occurs to any other persons/ public, the contractor shall pay necessary compensation and other expenses if so required, contractor shall initiate case for legal action against defaulter workman and such employee shall not be allowed to continue to work at site.

9.4 The contractor will take necessary precautions and due care to protect the material, while in his custody from any damage/ loss till the same is taken over by WBZA. In case of any theft of material under contractor's custody, matter shall be reported to police by the contractor immediately and copy of FIR and subsequently police investigation report may be initiated for claim with insurance agency .

10. For any purpose whatsoever, the employees of the contractor shall not be deemed to be in the employment of WBZA

11 GUARANTEE : In the event of the contractor failing to repair the defective works within the time specified by the Engineer, WBZA may proceed to undertake the repairs of such defective works at the contractor's risk and cost, without prejudice and recover the same from SD amount.

12 TERMS AND CONDITIONS FOR CIVIL, STRUCTURAL AND FINISHING WORKS

12.1 CONTRACTOR'S SITE OFFICE / SUPERVISION The Contractor shall establish an office at Site and keep posted an authorised, responsible officer with valid Power of Attorney for the purpose of the contract if the contractor himself not available during the progress. Any order or instructions of the Engineer or his duly authorised representative, communicated to the contractor's representative at site office will be deemed to have been communicated to the contractor at his legal address for immediate compliance .

12.2 SUPERVISORY STAFF AND WORKMEN

12.2.1 The contractor shall deploy all the experienced skilled, semiskilled and unskilled workmen required for all the works under this specification.

12.2.2 The supervisory staff including qualified Engineers deployed by the contractor shall ensure proper out-turn of work and discipline on the part of the labour put on the job by the contractor and in general see that the works are carried out in a safe and proper manner and in coordination with other labour and staff deployed directly by WBZA or other contractors of WBZA / other agency.

12.2.3 During the course of construction, if the progress is found unsatisfactory, or in the opinion of WBZA, if it is found that the skilled workmen like welder, fitters, technicians etc. deployed are not sufficient, contractor shall arrange more work force to cope up progress.

12.2.4 The Contractor shall ensure deposit of provident funds and get necessary ESI of their deployed workmen, employees at site and produce documents to WBZA in respect of these as desired by WBZA from time to time as per the Govt. rules.

12.3 TOOLS AND PLANTS / IMTEs

12.3.1 All T&Ps and IMTEs which are required for successful and timely execution of the work covered within the scope of this tender, shall be arranged and provided by the contractor at his own cost in working condition. Indicative lists of T&Ps and IMTEs to be arranged by the contractor as bar chart prepared for each item of work.

12.3.2 The day to day and routine maintenance of T&Ps should be carried out by contractor as per manufacturer's schedule at his cost. These shall be maintained in good working condition during the entire period of use. T&Ps in defective / damaged condition shall be rectified promptly to the full satisfaction of WBZA engineer. Contractor shall maintain records for maintenance of major T&Ps which shall be made available for Inspection whenever required. Any delay in progress shall be on contractor's account.

12.3.3 Increasing / shortening of the crane boom to suit work requirements shall have to be arranged by the contractor at his cost. All necessary manpower, tools, support, consumables, illumination etc. will have to be arranged by contractor at his cost.

12.3.4 consolidation of ground and arrangements of sleepers/ sand bag filling etc for

safe operation /movement of equipment including cranes/trailers etc shall be the responsibility of the contractor at his cost.

12.3.5 Contractor shall ensure deployment of serviced and healthy T&Ps including cranes, lifting tackles, wire ropes, Manila ropes, winches and slings etc. History card and maintenance records for major T&Ps will be maintained by the contractor and will be made available to WBZA Engineer for inspection as and when required. Identification for such T&Ps will be done as per WBZA Engineer's advice.

12.3.6 Retesting / re-calibration /standard Tape shall also be arranged at regular intervals during the period of use as advised by WBZA Engineer with in the contract price. The contractor will also have alternate arrangements for such IMTE so that work does not suffer when the particular instrument is sent for calibration.

13.0 MATERIALS

13.1 **WBZA will not supply any material.** All the material arranged by the contractor shall confirm these specifications and supported by the documentary proof for purchase of material from the authorised dealer and source.

13.2 All materials to be provided by the contractor shall be of best kind in conformity with the specifications laid down in the contractor or as per relevant Indian Standard/PWD SOR.

13.3 It shall be the responsibility of the contractor to obtain prior approval of WBZA, regarding suppliers, type of electrodes etc. before procurement of welding electrodes / TIG wires. On receipt of electrodes at site these shall be subjected to inspection and approval by WBZA. The contractor shall inform WBZA details regarding type of electrodes, batch No., date of expiry etc. and produce test certificate for each lot / batch with correlation of batch / lot number with respective test certificate. Without valid test certificate, the use of welding electrodes is prohibited.

14.0 Stacking and Storage of Materials

14.1 Fine Aggregate- it should be stacked on a dry brick pavement floor and should be made fit as per the required Zone by mixing the missing sizes. The detail of stacking, cleaning etc should be done as per PWD SOR and Zone should be followed as per IS Code.

14.2 Coarse Aggregate- it should also be stacked over the Brick pavement.

14.3 Reinforcement Steel- it should be placed as per the direction of the Authorized person of the Director.

14.4 The cement should be placed in dry room over wooden floor as per the direction/ PWD SOR. The cement brand, Date of Manufacturing etc all the details must be clearly visible over the waterproof bags of Cement.

NOTE-

It is to ensure while collecting the above materials for mixing that the natural surface soil is not mixed up with the above materials. If so happened, then it must be kept aside and should be washed before prior use.

15.0 Grid Layout Layout plan-

It should be got approved at site before commencement of work before excavation of foundation and got approved by Director's Authorized Person.

16.0 SITE DRAINAGE

16.1 All water including sub-soil water which may accumulate on the Site during the progress of the works or in trenches and excavations, including monsoon period shall be removed by the contractor from the Site to the satisfaction of the Engineer. It will also be responsibility of the contractor to de-water all the foundation pits, trenches with suitable de-watering methods like, pumping out, well point system etc. considering the depth of water table at plant site. All such expenditure on **de-watering** shall be deemed to be included in quoted rates.

Note- the casting of concrete work at shallow water ground level, the dewatering should be on continuous process at such location extra use of cement in concrete 10%-12% shall be insure as per IS code without any extra cost, same should be included in quoted rate.

17.0 SAFETY CODE

17.1 it is to note that Explosives shall not be used at work site by contractor except rare permitted by the "**Member Secretary**", WBZA. Where explosives are used, the same shall be stored in a special magazine to be provided by and at the cost of the contractor who shall be liable for all damages, losses and injury to any person or property and shall be responsible for complying with all statutory obligations in this respect. Further, the contractor is required to provide proper Safety Net System wherever the hazard of fall from height is present as per instructions of WBZA Engineer at site. The safety net shall be duly tested and shall be of ISI mark and the nets shall be located as per site requirement to arrest and avoid any consequences of a possible fall of persons working at different heights.

17.2 The contractor will be responsible for Health, Safety & Environment management at site for the construction activities to be carried out by them in accordance with safety rules and regulations.

17.3 Contractor shall ensure pre employment medical check for all staff & workers. And arrange adequate minimum First Aid facilities with trained staff. If necessary, contractor shall call ambulance to meet with required emergency treatment.

18.0 NUISANCE : The Contractor shall not at any time do, cause or permit any NUISANCE on Site or do anything which shall cause unnecessary disturbance or inconvenience to owners, tenants or occupiers of other properties near the Site and to the public generally.

19.0 MATERIAL OBTAINED FROM EXCAVATION

Materials of any kind obtained from EXCAVATION on the Site shall remain the property of WBZA and shall be disposed of as the Engineer may direct, at no extra cost.

20.0 TREASURE, TROVE, FOSSILS etc.

All fossils, coins, articles of value or antiquity and structures and other remains or things of geological or archaeological interest discovered on the site shall be the absolute property of WBZA and the Contractor shall take reasonable precautions to prevent his workmen or any other person from removing or damaging any such article or thing, shall immediately upon discovery thereof and before removal acquaint the Engineer with such discovery and carryout the Engineer's directions as to the disposal of the same.

21.0 PROTECTION OF WORKS

21.1 Trees designated by the Engineer shall be protected from damage during the course of the Works and earth level. Where necessary, such trees shall be protected properly.

21.2 The contractor shall provide and maintain at his own expense all lights, guards, fencing and watching when and where necessary or required by the Engineer for the protection of the Works or for the safety and convenience of those employed on the Works or the public.

21.3 The contractor shall have total responsibility for protecting his works till it is finally taken over by the Engineer. No claim will be entertained by the Engineer for any damage or loss to the contractor's works and the contractor shall be responsible for the complete restoration of the damaged works to its original condition to comply with the specifications and drawings. Should any such damage to the contractor's works occur because of other party not under his supervision or control, the contractor shall make his claim directly with the party concerned. The contractor shall not cause any delay in the repair of such damaged works because of any delay in the resolution of such disputes. The contractor shall proceed to repair the work immediately and no cause thereof will be assigned pending resolution of such disputes.

21.4 Contractor shall be fully responsible for the security of his workmen/ employees/ associates/all kinds of materials deployed by the contractor / tools and plants. Contractor shall also be responsible for the security of all the executed works, under execution works and completed works till the period it is fully taken over by WBZA.

22.0 RECORD FOR MATERIALS CONSUMED

The contractor shall maintain and furnish to the Engineer the RECORD OF MATERIALS consumed in the works for each activity. The statement showing the theoretical vis-à-vis actual consumption of specified materials, such as structural /reinforcement steel, cement, bitumen, lead, paint etc., shall be enclosed along with the Running Bills submitted by the contractor. Contractor has to also furnish the test results of the materials used in the work as per IS specifications.

23.0 PROTECTION OF EMBEDMENTS BOLTS ETC.

The contractor shall ensure proper protection to the satisfaction of the Engineer, of all bolts, inserts, embedment's etc. from weather etc/ by greasing, rapping them with gunny bags or canvas or by any other means as directed by Engineer. Cost of such protections shall be deemed to be included in the rates quoted for the item.

24.0 QUALITY ASSURANCE

The contractor has to establish / arrange at site the field testing facilities for testing of civil construction materials and concrete cubes for ensuring the proper quality, grade and strength of the materials used in the construction in line with approved field quality check list of WBZA. Contractor has to submit detailed report for testing of all material used etc. All testing shall be done as per IS code specifications/ WBZA's quality plan. If further test is required by the engineer to be carried from outside laboratory, the cost of the same shall be borne by the contractor.

25.0 METHOD OF MEASUREMENT-

Method of measurements shall be as per standard specification included in the tender. For other items, measurement shall be as per relevant IS CODE.

26.0 ARRANGEMENTS

26.1 WBZA shall try to assist and provide the Electric connection and water supply to the extent of availability with Zoo Authority on charges as admissible by the Concerning Authority. The contractor shall have their own arrangement for portable water required in access of the capacity to share water. Similarly, electric power supply as per line capacity available with the zoo authority shall share for the requirement but contractor should have its individual arrangements with DG set for construction purpose in access requirement and during load shedding.

26.2 For obtaining the connection the contractor shall install/ lay necessary pipelines and electric wiring covered in plastic conduits at his own cost.

27.0 PROGRESS REPORT-

Daily work progress report shall be maintained and the next day work should be carried out like curing, excavation, etc and discussed with the authorized person of Director.

PART – C

GENERAL TERMS AND CONDITIONS

1.0 DEFINITION OF TERMS

Throughout the Tender Documents including the Enquiry Letter, the following words shall have the meanings assigned to them herein, unless the subject matter or the context requires otherwise.

1.1 The '**Purchaser**' or '**WBZA**' shall mean West Bengal Zoo Authority incorporated under the Companies Act 1956, with its Registered Office at WBZA KB -19, Second Floor, Aranya Bikash Bhawan, Salt Lake City, Sector - III, Kolkata - 700098, which expression shall include its successors and assigns; acting through its Fabrication Plant (FP), or its authorised officers or its Engineer or other employees authorised to deal with any matters with which these persons are concerned, on its behalf.

1.2 The '**Tenderer**' shall mean the Firm/Company/Organisation, which quotes against the Tender Enquiry issued by the Purchaser. It may also be referred as '**Bidder**'.

1.3 The '**Contractor**' shall mean the individual, firm or company whose Offer is accepted by WBZA and enters into Contract with WBZA and shall include their executors, administrators, successors and permitted assigns.

1.4 The '**Contract**' shall mean and include the agreement, the work order, the accepted appendices of rates, Schedules of Quantities, if any, General Conditions of Contract, Special Conditions of Contract, Instructions to Tenderers, the drawings, the technical specifications, the special specifications, if any, the tender documents and the Letter of Intent/ Acceptance letter issued by WBZA. Any conditions or terms stipulated by the Tenderer in the tender documents or subsequent letters shall not form part of the Contract unless specifically accepted in writing by WBZA in the Letter of Intent and incorporated in the Agreement. It may also be referred as '**Contract Document**'.

1.5 The '**Sub-contractor**' shall mean the person/firm/company/organisation to whom any part of the work has been sub-contracted by the Supplier, with the written consent of the Purchaser and shall include his heirs, executors, administrators, representatives and assigns.

1.6 The '**Engineer**', for the purpose of this Contract shall mean an engineer, person or company duly appointed as such from time to time or such other officials as may be duly authorised and appointed and notified in writing by purchaser to act as engineer. In cases where no such Engineer has been so appointed, the word 'Engineer' shall mean the Purchaser or his duly authorised representative. It may also be referred to as '**Engineer –in –Charge**'.

1.7 The '**Equipment**' shall mean and include plant and stores on which work is to be done by the Contractor under the Contract.

1.8 The **'Work'** shall mean and include supply of all categories of labour, specified consumables, tools and tackles required for complete and satisfactory construction, site transportation, handling, stacking, storing, erecting, testing and commissioning of the equipment; as defined in the Tender Documents, to the satisfaction of WBZA. It may also be referred as **'CONTRACT WORK'**.

1.9 The **'Tender Document'** shall mean and include the instruction to Tenderers, general conditions, bidding conditions, specific conditions, specifications, schedules, drawings, form of tender, schedule of prices and quantities, contained in the Tender and any subsequent modifications thereof.. It may also be referred as **'Tender Specification'**

1.10 The **'Offer'** shall mean and include the technical and commercial documents including specifications, schedule of prices and quantities, drawings etc submitted by the Tenderer in response to the tender enquiry and any subsequent clarifications thereof. It may also be referred as **'Bid'**.

1.11 **'Acceptance of offer'** shall mean issue of letter of intent/award or memorandum or detailed Order/Contract communicating the acceptance of offer, to the successful Tenderer.

1.12 The **'Letter Of Intent'** shall mean the intimation by a letter / fax to the Tenderer that the tender has been accepted in accordance with provisions contained in the letter. The responsibility of the contractor commences from the date of issue of this letter and all the terms and conditions of contract are applicable from this date.

1.13 The **'Site'** shall mean the site of the proposed work at place for which NIT published by the MEMBER SECRETARY, WBZA .

1.14 The **'Completion Time'** shall mean the period specified in the Letter of Intent or date mutually agreed upon for completing the work to the satisfaction of the Engineer, being of required standard and conforming to the specifications of the Contract including extension period.

1.15 The **'Tests'** shall mean and include such test or tests to be carried out by the Contractor as are prescribed in the Contract or considered necessary by the Member Secretary, WBZA in order to ascertain the quality, workmanship, performance and efficiency of the contracted work or part there off.

**Abstract Cost of Estimate
for**

PROPOSED COST ESTIMATE FOR STORE CUM KITCHEN AT SUNDARBAN WILD ANIMAL PARK, JHARKHALI

B.SCHEDULED ITEMS

THE RATES ARE AS PER P.W.D. SCHEDULE (BUILDING, VOL - I) w.e.f. 01-11-2017)

SI No	Description of work	Quantity	Unit	Rate Rs. P.	Cost	Rs. P.	Reference
1	Earth work in excavation of foundation trenches or drains, in all sorts of soil (including mixed soil but excluding laterite or sandstone) including removing, spreading or stacking the spoils within a lead of 75 m. as directed. The item includes necessary trimming the sides of trenches, levelling, dressing and ramming the bottom, bailing out water as required complete. (a) Depth of excavation not exceeding 1,500 mm.	100.00	Cu.m	119.27	11927.00		P-1 / I - 2(a)
2	Earth work in filling in foundation trenches or plinth with good earth, in layers not exceeding 150 mm. including watering and ramming etc. layer by layer complete. (Payment to be made on the basis of measurement of finished quantity of work) (a) With earth obtained from excavation of foundation..	66.00	Cu.m	77.54	5117.64		P-1 / I - 3(a)
3	(A) Filling in foundation or plinth by silver sand in layers not exceeding 150 mm as directed and consolidating the same by thorough saturation with water, ramming complete including the cost of supply of sand. (payment to be made on measurement of finished quantity)	17.00	Cu.m	1048.41	17822.97		P-2 / I - 4
4	Single Brick Flat Soling of picked jhama bricks including ramming and dressing bed to proper level and filling joints with local sand.	103.00	Sq.mt.	358.00	36874.00		P-14 / I -1
5	Ordinary cement concrete(mix 1:1.5:3) M20 with graded stone chips (20mm nominal size) excluding shuttering and reinforcement, if any as per relevent IS codes. Pakur varity						P-26 / 10 / (i)
	a) In Ground floor	70.00	Cum	6000.00	420000.00		
6	Ordinary cement concrete (mix 1:3:6) with graded stone metals (37mm nominal size) excluding shuttering and reinforcement, if any, in ground floor, as per relevent IS codes. Pakur varity						P-24 / 21 / (4)
	STONE META L.	11.00	Cum	5000.00	55000.00		
7	Hire and labour charges for shuttering with centering and necessary staging upto 4m. using approved (use steel prop/ bullah prop) and thick hard wood planks of approved thickness with required bracing for concrete slabs, beams, columns, lintels etc. curved or straight including fitting, fixing and striking out after completion of works .						P-43 / I-36/ (C)
	(a) 25 mm to 30 mm thick wooden shuttering as per decision & direction of Engineer-In-Charge.						
	(i) Upto roof of Ground Floor.	350.00	Sqm	335.00	117250.00		
8	Reinforcement for reinforced concrete work in all sorts of structures including distribution bars, stirrups, binders etc initial straightening and removal of loose rust (if necessary), cutting to requisite length, hooking and bending to correct shape, placing in proper position and binding with 16 gauge black annealed wire at every intersection, complete as per drawing and direction.						P-43/ I-40(a)(i)(I),

SI No	Description of work	Quantity	Unit	Rate Rs. P.	Cost Rs. P.	Reference
	(a) In foundation, basement and upto roof of ground floor/upto 4 M.	9.50	MT	58249.00	553365.50	
9	Brickwork with 1st. class bricks in cement mortar (4:1)					P-15 / I-7b
	(i) In foundation and plinth.	0.00	Cum	5103.00	0.00	
	(ii) In Superstructure, Ground floor.	31.00	Cum	5529.00	171399.00	
10	125 mm thick brickwork with 1st class bricks in cement mortar (4:1)					P-16 / I - 16& 18
	(a) In Ground floor.	100.00	Sqm	724.00	72400.00	
11	Labour for chipping of concrete surface before taking up plastering work.	800.00	Sqm	21.00	16800.00	
12	Plaster (to wall, floor, ceiling, etc.) with sand and cement mortar including rounding off or chamfering corners as directed and raking out joints including throating, nosing and drip course, scaffolding /staging where necessary. (Excluding cost of chipping over concrete surface.)					
	(A) With 1:4 cement mortar					
	(i) 20 mm. thick plaster					
	(a) In Ground Floor	140.00	Sqm	167.00	23380.00	P-189 / I-1 (ii)(a)
	(ii) 15 mm thick plaster					
	(a) In Ground Floor	400.00	Sqm	145.00	58000.00	P-189 / I-1 (ii)(c)
	(iii) 10 mm. thick plaster with cement motor 1:4	250.00	Sqm	129.00	32250.00	
13	Net Cement punning to wall, floor, dado	50.00	Sqm	34.00	1700.00	P-191 / I-11
14	Supplying, fitting and fixing Shallow water closet Indian pattern (I.P.W.C.) of approved make in white vitreous chinaware in position (excluding cost of concrete for fixing). - 510 mm long	1.00	Nos.	1098.00	1098.00	P-74/ I - 1 (Vol-II)
15	Construction of septic tank of different capacities as per approved drawing with 1st class brick work in cement mortar (1:4) including two 560 mm dia. R.C.C. manhole over (heavy type) of approved make supplied, fitted and fixed in the 100mm thick R.C.C (1:1.5:3) top slab with necessary fittings, 20mm thick cement plaster (4 : 1) with neat cement finish to the internal surfaces and 15 mm thick cement plaster (4 : 1) to outside wall upto 200 mm below G.L floor finished with 25 mm thick grey artificial stone over 100 mm thick R.C.C(1:1.5:3) bottom slab including supplying, fitting and fixing all necessary specials, fittings, S.W. tees, C.I. foot rest etc. including excavation earth in all sorts of soil, shoring, bailing out and pumping out water as necessary, ramming, dressing the bed and refilling the sides of the tanks with earth, removing spoils, filling up the chamber with clear water, removing foreign materials from the chamber and including constructing attached inspection pit as per approved drawing and connecting all necessary pipes, joints etc. with internal plaster work and	1.00	Nos.	39541.00	39541.00	P-85/ I - 3 (Vol-II)

SI No	Description of work	Quantity	Unit	Rate Rs. P.	Cost Rs. P.	Reference
16	Construction of circular soak well 2.5 metre deep in all types of sandy soils with dry brick work upto 1.6 metre from the bottom having 150 mm intermediate cement brick work (1:4) band all round and cement brick work (1:4) upto 0.90 metre from top with 20mm thick cement plastering (1:4) to inside face upto the depth of cement brick work, 15mm thick cement plaster (1:4) on outer face from top of the well upto G.L. and 6 mm thick cement plaster (1:4) on top of the R.C.C. cover slab including filling bottom 1.00 metre of inside of the well with brick metal (50 mm to 63 mm size) including R.C.C. cover slab of 100 mm thick with cement conc (1:1.5:3) with stone chips with necessary reinforcement and shuttering including one 560 mm dia. R.C.C. manhole cover (heavy type)of approved make supplied, fitted and fixed in the cover slab with necessary fittings, making necessary arrangements for pipe connections, excavation of well including shoring, dewatering and removing the excess earth from the premises as per direction complete in all respect with all costs of labour and materials. With 250 mm thick dry brick work and 250 mm thick cement brick work (1:6) and 1.00m inside dia.	1.00	Nos.	17911.00	17911.00	P-85/ I - 4 (Vol-II)
17	Supplying, Fitting & Fixing 30 mm thick both side prelaminated Factory made solid Panel PVC Door Shutter consisting of outer frame made out of M.S. tubes of 19 gauge thickness and size 19 mmx19 mm for styles, top and bottom rails, M.S. frame shall have cost of steel primers of approved make and manufacture, M.S. frame covered with 5 mm th. heat moulded PVC "C" channel of size 30 mm th, 70 mm width out of which 50 mm shall be flat and 20 mm shall be tapered in 45 degree angle on either sides forming styles; and 5 mm th. 95 mm wide PVC sheet out of which 75 mm shall be flat and 20 mm tapered in 45 degree on the inner side to form top & bottom rail and 115 mm wide PVC sheet out of which 75mm shall be flat and 20 mm shall be tapered on both sides to form lock rail. Top, bottom and lock rails s all be provided either side of the panel with 10 mm (5 mmx2) th.,20 mm wide cross PVC sheet as gap insert for top rail and bottom rail sheet to be fitted in the M.S. frame welded/sealed to the styles &rails with 7 mm (5 mm+2 mm) th.x15 mm wide PVC sheet beading on inner side and joined together with solvent cement adhesive. An additional 5 mm th. PVC strip of 20 mm which is to be stuck on the interior side of the "C" channelusing PVC solvent adhesive etc. complete excluding all necessary hardwares as per direction of Engineer-in-Charge	3.00	Sqm	2868.00	8604.00	P-145 / I -146
18	Water proof treatment on roof as per specification	110.00	Sqm	679.00	74690.00	P-89 / I - 1
19	Cement washing including cleaning & smoothing the surface thoroughly. (2 coats)	800.00	Sqm	49.00	39200.00	P-194 / I- 5
20	Colour washing (2 coats) External Surface	180.00	Sqm	21.35	3843.00	P-194/I-42

SI No	Description of work	Quantity	Unit	Rate Rs. P.	Cost	Rs. P.	Reference
21	Wood work in door and window frame fitted and fixed in position complete including a protective coat of painting at the contact surface of the frame excluding cost of concrete, Iron Butt Hinges and M.S clamps. (The quantum should be corrected upto three decimals). - Sal : Local.	1.00	Cu.mt.	77671.00	77671.00		P-114 / I-1(d)
22	Z batten shutters with 25mm thick plank and 90mm thick batten as per specificationk. (sisu or chap wood)	26.00	Sqm	2750.00	71500.00		P-123 / I- 10(a) (iii)
	(a) Glazed shutter 35mm thick sisu or chap wood as per specification	0.20	Sqm	2752.00	550.40		P-119/I-4(ii)
23	M.S.or W.I. Ornamental grill of approved design joints continuously welded with M.S, W.I. Flats and bars of windows, railing etc. fitted and fixed with necessary screws and lugs in ground floor.	400.00	Kg.	72.38	28952.00		P-104 / I -13(i)
24	35 mm thick Artificial stone in floor, dado, staircase etc with cement concrete (1:2:4) with stone chips, laid in panels as directed with topping made with ordinary or white cement (as necessary) and marble dust in proportion (1:2) including smooth finishing and rounding off corners including raking out joints or roughening of concrete surface and application of cement slurry before flooring works using cement @ 1.75 kg/sq.m all complete including all materials and labour. In ground floor. 3 mm. thick topping (High polishing grinding on this item is not permitted with ordinary cement). Using grey cement	110.00	Sqm	330.00	36300.00		P-48 / I- 6
25	Priming one coat on timber or plastered surface with synthetic oil bound primer of approved quality including smoothening surfaces by sand papering etc.						P-176 / I- 7(a)
	(a) Wood work	110.00	Sqm	38.00	4180.00		
	(b) On steel work	15.00	Sqm	29.00	435.00		
26	Painting with best quality synthetic enamel paint of approved make and brand including smoothening surface by sand papering etc. including using of approved putty etc. on the surface, if necessary : Two coats (with any shade except white)						P-176 / I- 8(iv)
	a) On Wood work	110.00	Sqm	78.00	8580.00		
	(b) On steel work	15.00	Sqm	79.00	1185.00		
27	Supplying, fitting & fixing 1st quality Ceramic tiles in walls and floors to match with the existing work & 4 nos. of key stones (10mm) fixed with araldite at the back of each tile & finishing the joints with white cement mixed with colouring oxide if required to match the colour of tiles including roughening of concrete surface, if necessary or by synthetic adhesive & grout materials etc. - With Sand Cement Mortar (1:4) 20 mm thick & 2 mm thick cement slurry at back side of tiles using cement @ 2.91 Kg/Sq.m & joint filling using white cement slurry @ 0.20kg/Sq.m.	10.00	Sqm	799.00	7990.00		P-64 / I- 35(iii)
28	Collapseble gate as per specification	5.00	Sqm	3402.00	17010.00		P-106/I-18
	Sub-total				2032526.51		

SI No	Description of work	Quantity	Unit	Rate Rs. P.	Cost	Rs. P.	Reference
	Add, Sanitary & Plumbing and water supply and Electricity Expenses 10%					203252.65	
	Gross Total					2235779.16	
	GST %18%					402440.25	
	Total (A)					2638219.41	
	Labour Surcharge 1% of (A)					26382.19	
	Contingency 3%					79146.58	
	Grand Total					2743748.19	



FRONT ELEVATION

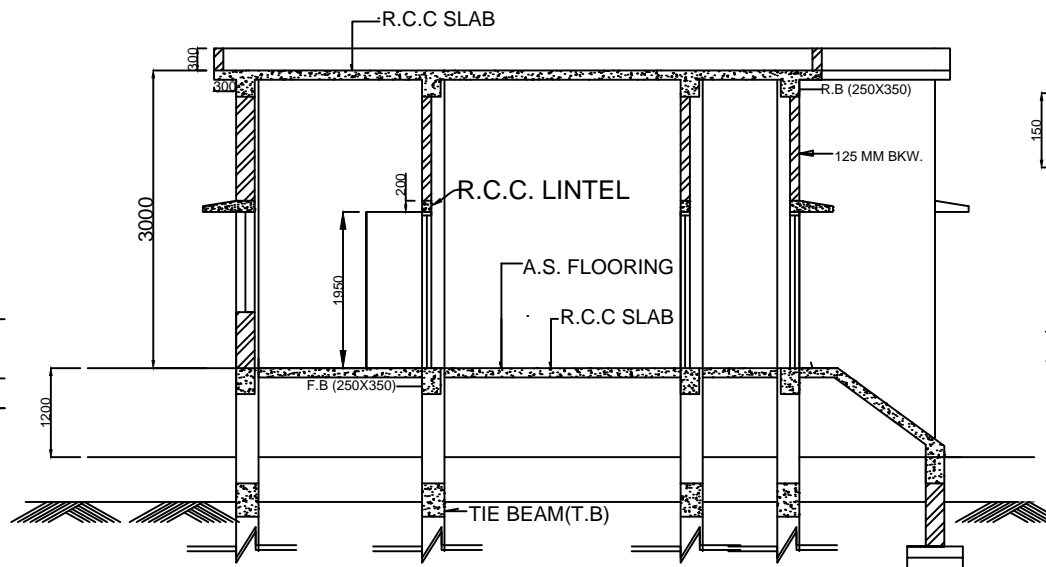

SECTION ON -- A-A

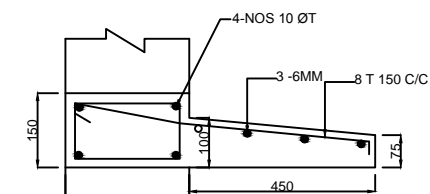

DETAIL OF LINTEL & CHAJJA

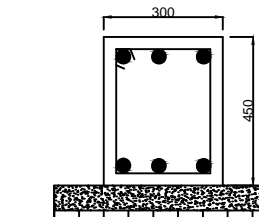

DETAIL OF TIE BEAM

T.B. -AT O.G.L
 F.B.- AT FLOOR LEV.
 R.B. -AT ROOF LEV.

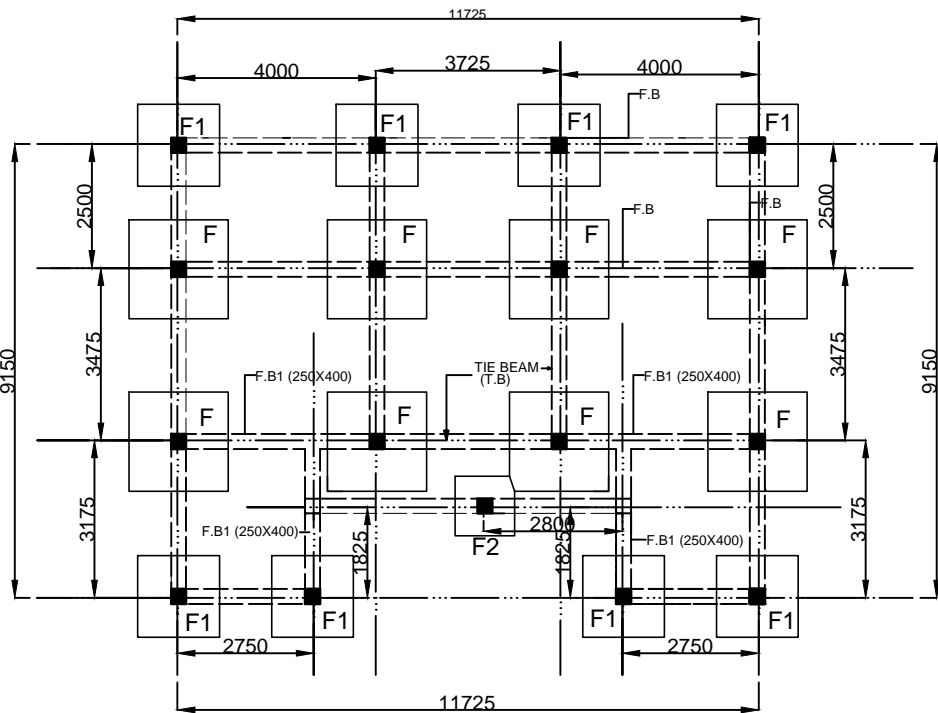

FDN. LAYOUT PLAN
 (SCALE = 1:100)

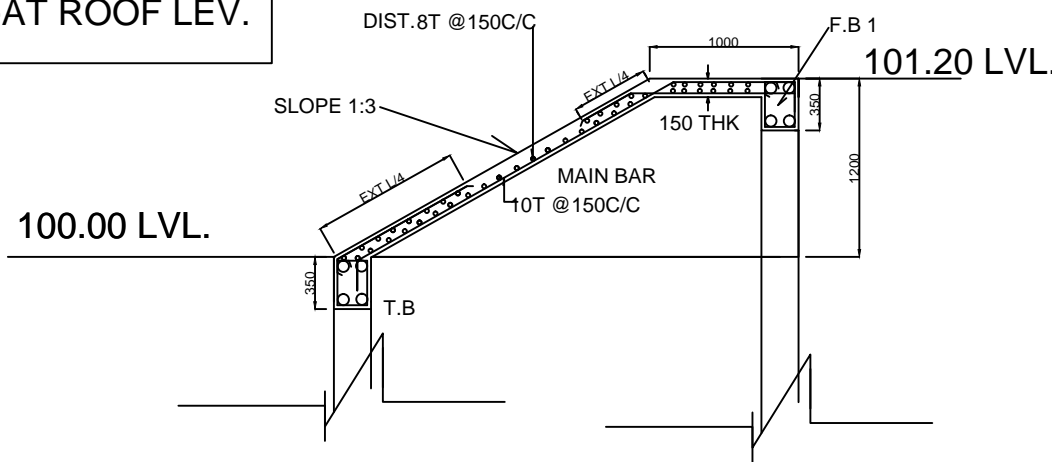

DETAILS OF RAMP

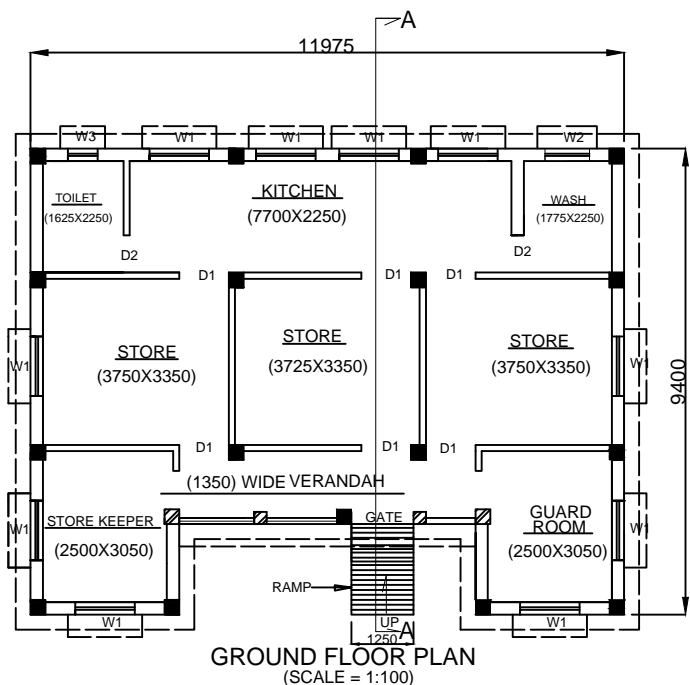

GROUND FLOOR PLAN
 (SCALE = 1:100)

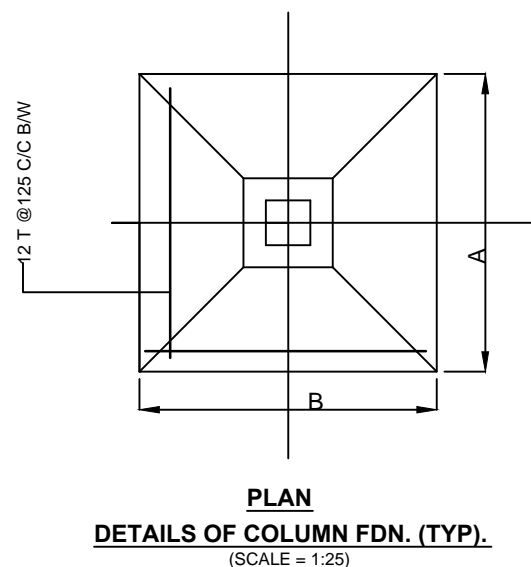

PLAN
 DETAILS OF COLUMN FDN. (TYP.)
 (SCALE = 1:25)

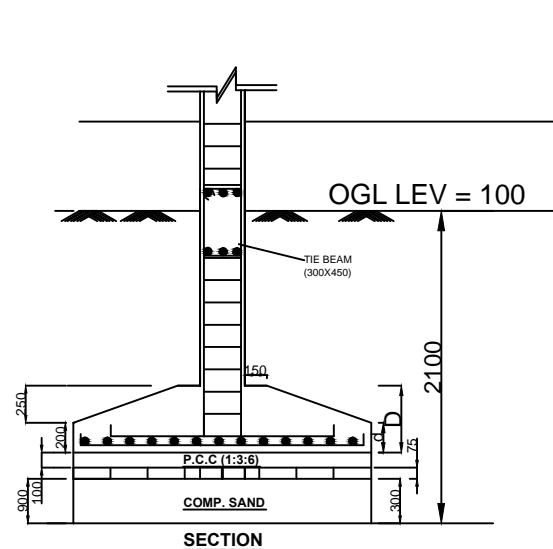

SECTION

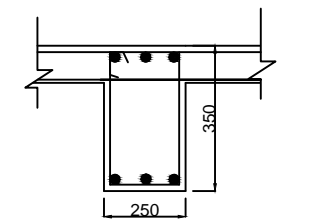

SECTION OF BEAM (TYP)

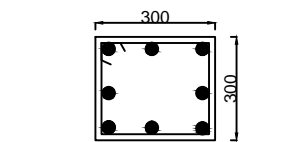

SECTION OF COLUMNS.

SCHEDULE OF COLUMNS FDN.

FDN MKD	FDN SIZE A X B	d	D	REINFT
F	2000X2000	200	450	10 T @ 125 C/C B/W
F1	1650X1650	200	400	10 T @ 150 C/C B/W
F2	1200X1200	200	350	10 T @ 150 C/C B/W

COLUMN SCHEDULE .

COL. MKD	SIZE	VER. BAR	STRP.
ALL COLUMNS	300X300	4- 16 T. 4- 12 T.	8 TOR @ 150 C/C

SCHEDULE OF BEAM

MKD	SIZE B X D	BOT (ALTH)	TOP(ALTH)	STIRRUP
T.B	300X450	3- 16 T	3- 12 T	8 TOR @ 150 C/C
F.B/R.B	250X350	3- 12 T	3- 12 T	8 TOR @ 150 C/C
F.B 1	250X400	3- 16 T	3- 16 T	8 TOR @ 150 C/C

SLAB SCHEDULE

THK.	REINFORCEMENT.
125 MM	8 T @150 C/C ALT. CKD.

DOOR AND WINDOW SCHEDULE

MKD	WIDTH	HIGHT	NOS	REMKs.
D1	1000	1950	7	Z.- BATTEN
D2	750	1950	2	DO
W1	1200	1200	10	DO
W2	900	1200	1	DO
W3	600	600	1	GLAZED

ALL MEASUREMENTS ARE IN MM.

ALL OUTER WALLS 250 MM THK.

ALL PARTY WALLS 125 MM THK.

ALL R.C.C WORKS M 20 . GR.

TITLE

FOUNDATION,COLUMNS,TIE BEAM,LAYOUT
 PLAN,SCHEDULE OF COL,BEAM,AND SLAB.

COVERED AREA = 102 SQM.

SCALE: 1:100, 1:25

DRAWN BY =

CHECKED BY =